

FLOW METER WITH FLOAT – type K

I. APPLICATION

All-metal flow meters with float – type K are used for signalling and measuring of momentary flow, if need be flowed volume of liquid and fluent materials. In respect of their massive, all-metal (stainless) construction or lining of measuring part with PP, PVDF or PVC, they are highly resistant to physical and chemical agents. They are suitable for using in extreme service conditions of especially chemical, energetic, machinery, mining, food-processing industries, of material distribution in sewage works and water treatment plant, etc.



II. MEASURING PRINCIPLE

The flow meter is located right into the piping vertically $\pm 1\%$, where the measured material flows in the bottom-up direction. (Before the flow meter installation it is necessary to clean the pipe and rinse it out.) The float with magnet freely moves in the measuring part of the flow meter and it is stable in specific position accordance to the flow of measured material. Momentary position of the float is transferred by means of a magnetic connector to the indicator scale. The distance between the device and ferromagnetic materials or the distance among devices has to be 20 cm at least.

The devices must not be located in a strong magnetic field.

In case of dirty liquids measuring, it is possible to equip the flow meter inlet with the mechanical or magnetic filter.

This type of flow meter (up to size DN 25) is equipped with the vibration damper located by means of joint system and with the overload protection for measuring of fluent material. This construction is great at low hysteresis.

This flow meter does not require straight smooth lengths of pipes either at an inlet or at an outlet.

Precise local indication of momentary flow values directly on the flow meter scale is possible, by request of the Customer, to complete with limit contacts SP5, that read minimal or maximal momentary flow; or to complete with the contact SP6 with electrical output 4 – 20 mA, or with the evaluation device for the indication of momentary flow or/and flowed volume – i.e. totalizer.

In the ambient with explosion hazard, there is possible to use flow meters with all-metal measuring parts. The device may be connected only in a circuit followed with the sparking safeguarding device, which is certified for the design II(2) G [EEx ia] II C T6 with the supply secured from sparking at least. Practically the device produces no warming.

III. BENEFITS

Measuring part K:

- Measuring part is stainless, standard, resistant to high pressure and temperature
- Conical measuring cone, or float according to specific measuring conditions
- Magnetic transfer of float motion to the pointer motion is realised by means of high power magnetic materials with min. ageing influence
- Dumping of float motion – special ball joints construction with min. hysteresis
- Measuring part can be equipped with electrical or steam heating

Measuring part K lined with plastic:

- Measuring part is resistant to extreme mechanical and chemical straining
- Suitable for measuring of most of acids and alkali

Local indicator

- Direct indication of momentary flow by the pointer on the scale in fixed units
- Type for material high temperatures with the indicator offset and shielding

Limit contacts and converters

- One or two limit contacts SP 5
- Converter ECLM with linear outlet 4 – 20 mA,
11 – 26 Vss for Ex
11 – 36 Vss ambient without explosion hazard
- Evaluation device DMK with momentary flow indication
- Evaluation device ERT 50000 with indication of momentary flow and flowed volume
- Universal sectional unit PAX-D with indication of momentary flow and flowed volume

Physical engineering laboratory institute granted the Certificate FTZÚ 01 Ex0130X for flow meters type K with indicators P and V, design II2GEExia IICT6 for using in the ambient with explosion hazard.

IV. TECHNICAL DATA:

Type	K
Measuring range (100% of flow) choose from the table Water 20°C Air 101,3 kPa abs. , 20°C	1 up to 250.000 l / hr 0,18 up to 1300 m ³ / hr
Rate of max. and min. measured values	10 : 1
Measuring fault (in % from the rate) KP and KV KP-PP, KV-PP	± 1,6 ± 2,5
Measuring fault (in % from the rate) Additional fault of electrical outlet	± 2,5% ± 1%
Measuring part KP, KP-PP, KV and KV-PP	Metal tube with measuring cone or shield Metal tube with measuring cone or shield lined with PP, PVDF, PVC – acc. to measured material
Float type	Conical Conical with damping Cylindrical Material – stainless steel DIN 1.4541, DIN 1.4571, titanium PP, PVDF, PVC - acc. to measured material
Scale	In flow units (by the Customer's request)
Rated diameters	DN 15 up to DN 200
Shielding	IP 65, with angular connector IP 54
Flange connection acc. to CSN	DN 15 up to DN 200 DN 15 and DN 25/PN16 or Ermeto 12 – heating Food-processing connection acc. to DIN 11851
Max. working temperature of measured material in accordance with thermal category Thermal category T6 Thermal category T5 Thermal category T4 Thermal category T3	85° C 100° C 125° C 150° C
Max. working temperature of measured material without sensors using, max. ambient temperature ≤120°C KP and KV KP- PP, KV – PP KP – PVC, KV –PVC	300°C higher by request 150°C 60°C
Max. ambient temperature with using of SP6 sensors – analogue output Max. ambient temperature with using of sensors in ambient with explosion hazard Max. ambient temperature with using of sensors SP5, SP6 – analogue output, converter outside flow meter	85°C (acc. to temperature of measured material) 60°C 130°C

Requirements to other technical data have to be discussed with the producer.

MEASURING RANGES

DN	Type	Measuring range l/h	Measuring range m ³ /h
		Water 20°C	Air 20°C, 101,3 kPa
15	K1	1-40	0,18-1,2
15	K12	6-60	0,22-1,8
15	K13	10-100	0,30-3,0
15	K14	16-160	0,45-4,5
15	K15	25-250	0,70-7,5
15	K16	40-400	1,10-11
15	K17	54-540	1,30-13
15	K18	65-650	1,60-16
15	K19	100-1000	1,90-19
25	K21	68-680	1,70-17
25	K22	100-1000	2,00 -20
25	K23	160-1600	3,00 -30
25	K24	190-1900	3,40-34
25	K25	280-2800	4,00-40
25	K26	280-2800	6,00-60
25	K27	350-3500	10,00-100
25	K28	450-4500	14,00-140
50	K51	400-4000	5,00-50
50	K52	490-4900	7,00-70
50	K53	580-5800	9,00-90
50	K54	800-8000	11,00-110
50	K55	1100-11000	13,00-130
50	K56	1400-14000	15,00-150
50	K57	1900-19000	22,00-220
50	K58	2500-25000	26,00-260
80	K81	2600-26000	28,00-280
80	K82	3000-30000	30,00-300
80	K83	3500-35000	35,00-350
80	K84	3900-39000	50,00-500
100	K100	4000-30000	80,00-800
100	K101	6300-63000	120,00-1200
125	K121	5000-50000	130,00-1300
125	K122	5500-75000	
125	K123	6000-83000	
125	K124	15000-150000	
150	K151	5000-50000	
150	K152	5500-55000	
150	K153	7500-75000	
150	K154	10000-100000	
150	K155	12500-125000	
200	K201	14000-140000	
200	K202	19000-190000	
200	K203	25000-250000	

Above mentioned data are valid for materials mentioned in the table. For other liquid and fluent materials or their mixtures, the measuring ranges will be calculated and set up in accordance with temperature, pressure, density and viscosity of measured material.

KP, KP-PP, KP-PVC with flange connection

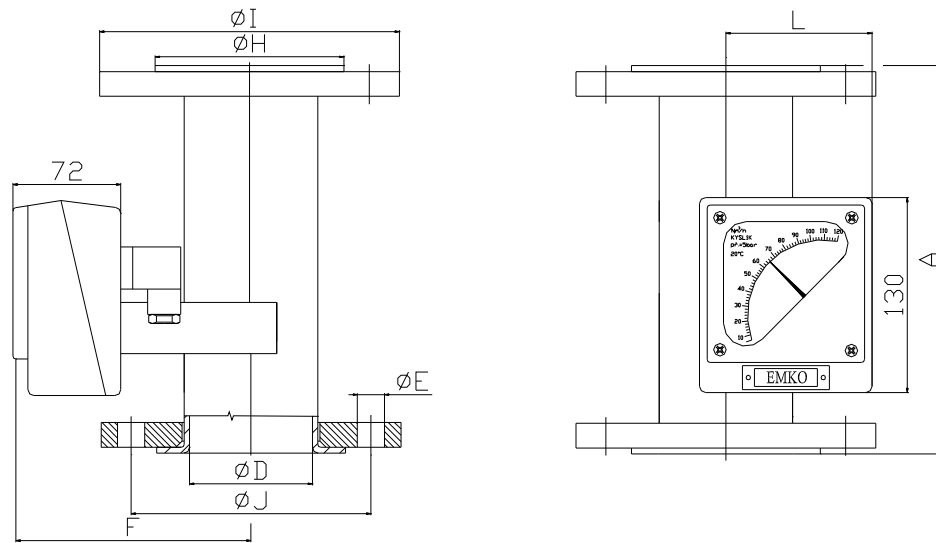

Total connection dimensions, weights of flow meters KP, KP-PP, KP-PVC with flange connection

DN	A	D	H	J	I	E	F	L	Weight kg
15	250	23	45	65	90	4xØ14	112	65	2,4
25	250	33	60	85	110	4xØ14	112	65	3
50	250	60	90	125	155	4xØ18	112	77	6
80	400	80	110	160	190	8xØ18	130	90	8,5
100	400	110	148	180	210	8xØ18	150	105	15
125	500	142	188	210	245	8xØ18	180	130	27
150	550	160	212	240	280	8xØ22	210	170	35
200	600	210	268	295	335	12xØ22	250	220	45

KV, KV-PP, KV-PVC with flange connection

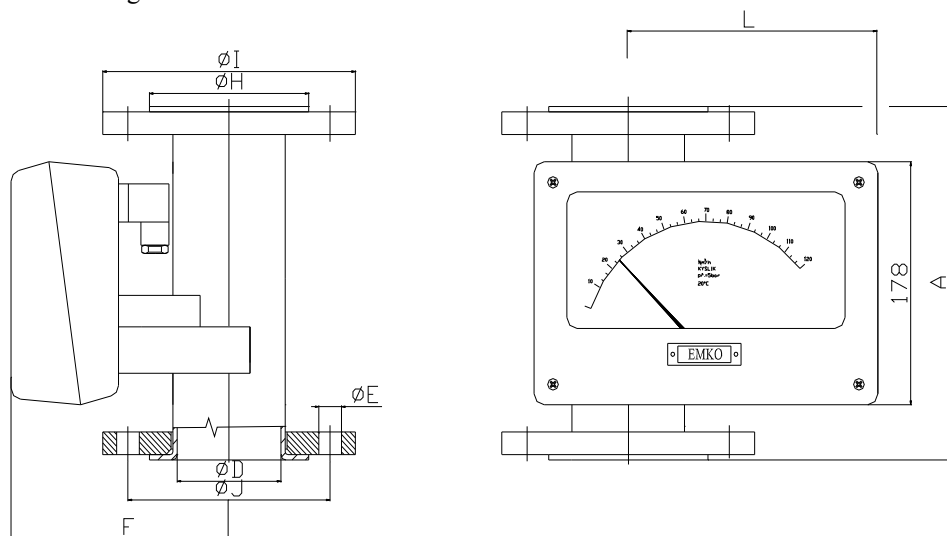

Total connection dimensions, weights of flow meters KV, KV-PP, KV-PVC with flange connection

DN	A	D	H	J	I	E	F	L	Hmotnost kg
15	250	23	45	65	90	4xØ14	112	147	2,8
25	250	33	60	85	110	4xØ14	112	147	3,4
50	250	60	90	125	155	4xØ18	112	160	6,4
80	400	80	110	160	190	8xØ18	130	172	8,9
100	400	110	148	180	210	8xØ18	150	187	15,4
125	500	142	188	210	245	8xØ18	180	212	27,4
150	550	160	212	240	280	8xØ22	210	252	35,4
200	600	210	268	295	335	12xØ22	250	300	45,4

V. ASSEMBLY, SERVICE AND MAINTENANCE

The flow meters are located in the piping vertically + 1° inlet from below. Before the flow meter installation it is necessary to **clean** the pipe and **rinse** it out. Service and maintenance present only the inspection of the tightness, filter cleaning at the inlet, if it is installed.

If it is necessary, clean the magnetic float, which is possible to take out from the flow meter:

1. The flow meter with the crossbar guide of a float and damping in the upper part of the flow meter. Take out the retaining ring in the upper part of the device and take out the damping cylinder. Loosen (best by the special spanner) the nut and the bottom cross of the float; take out the float, clean it and also the internal space of the device.
2. The flow meter with the bar guide of a float and damping in the bottom part of the flow meter. Take out the retaining ring in the upper part of the device and take out the upper guide of the float and then the float itself. Clean the float and also the internal space of the flow meter. Some types of flow meters have the possibility to take out also the bottom-damping cylinder.

The damping is used for measuring of compressible materials.

Adjusting or reduction valve has to be located into the piping in such a way to secure fixed pressure value in the flow meter and corresponding to the value mentioned at the device scale. In like manner secure the temperature values.

This flow meter does not require straight parts of pipes either at inlet or at outlet. The device is not suitable to use in the ambient with strong magnetic fields.

To connect conductors to angular connector located at the backside of the flow meter, in case of using limited contacts, current outlet or connection of external evaluation devices, follow this chart:

Flow meter type K - P

Flow meter type K - V

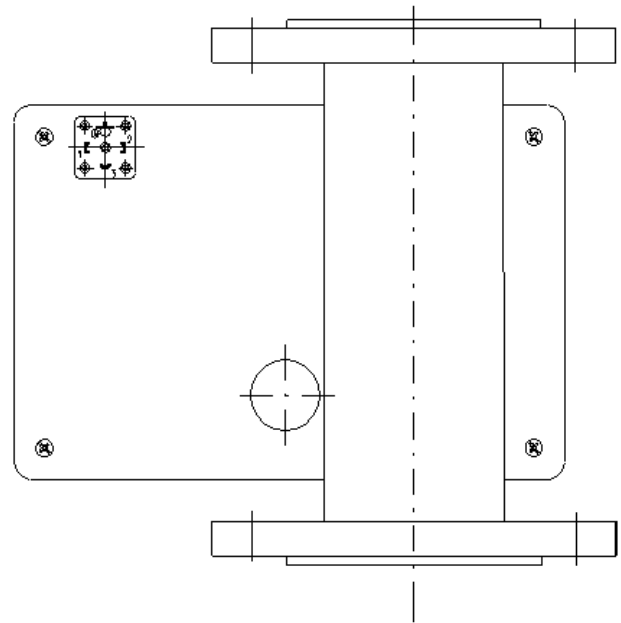
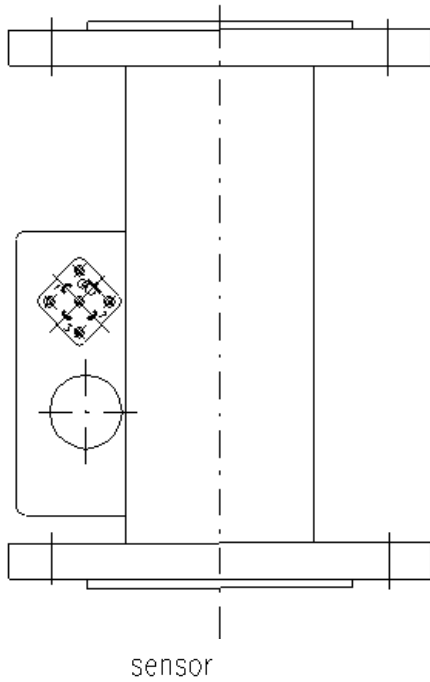

SP 5 min., contact closed at the flow fall
 SP 5 max., contact closed at the flow increase

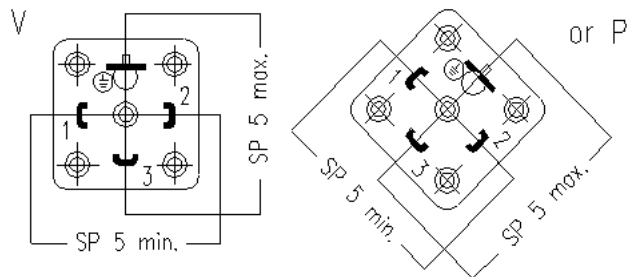

Wiring diagram of the flow meter output 4-20mA type EMKO-ECLM

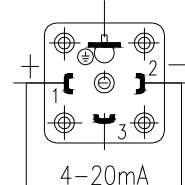

Power supply from the current loop 11 up to 36 Vss
 11-26 Vss Ex

Wiring diagram of the flow meter to the converter with separated indication of momentary flow type EMKO-ECLM with the display

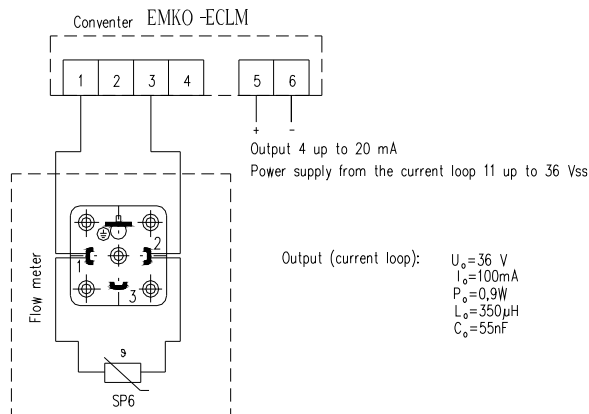

Possible corrections of a circuit resistance:
 Specify in your order or during the adjusting the size of the total circuit resistance Rv.
 Screw clamps are instrumental to the connection of conductors with profile from 0,5 to 1,5 mm².



Flow indicator ERT50000

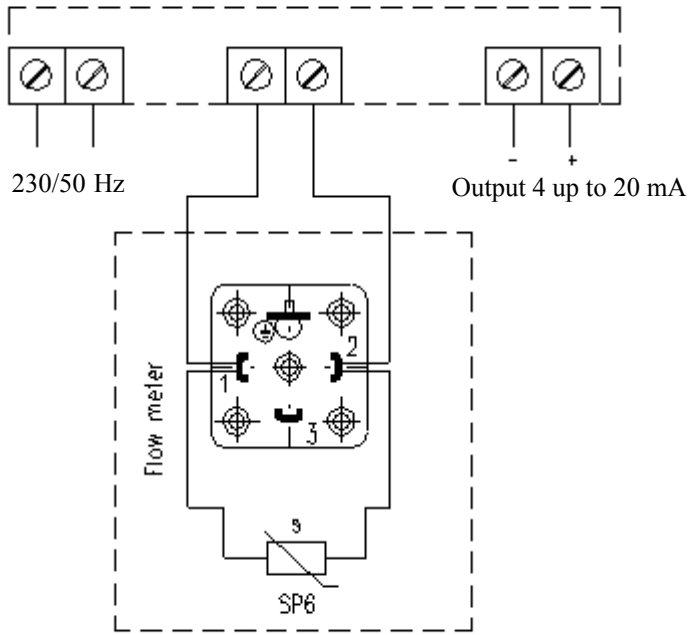

Technical data:

Power supply: 230V/50Hz
 Input: 3VA
 Display: 8 digits LCD height 11,7 mm
 Current output: active 4 – 20 mA or 0 – 20 mA
 $R_{max}=500\Omega$

Universal sectional unit PAX-D

Sectional unit displayed the momentary flow or the flowed volume with the possibility of 4 alarms. Current output: 4 – 20 mA or 0 – 20 mA

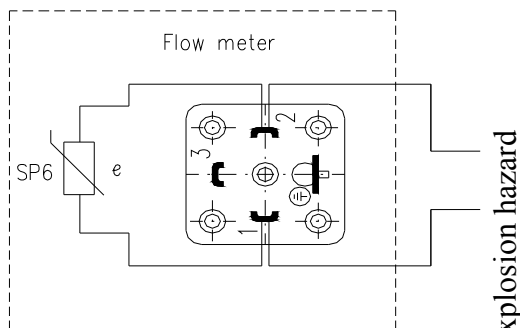

Ambient with explosion hazard

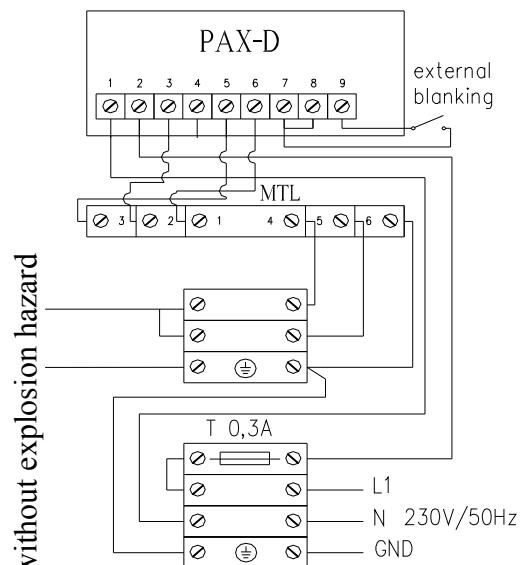

Ambient without explosion hazard

VI. ACCESSORIES

EMKO – flow meter – flow-keeper is possible to equip with sensors of flow volume

a) limit contacts -SP 5 min contact closed at the flow fall

-SP 5 max contact closed at the flow increase

Limit contacts SP 5 are monostable and adjustable in 10 – 20% of max. value of momentary flow measuring. Make it as follows:

a) Indicator P with dimensions 130 x 115 mm - screw off 3 pcs bolts M 5 with an internal hexagon on the back side of the case

b) Indicator V with dimensions 178 x 272 mm - screw off 4 pcs bolts M 4 on the front side of the case

- Remove the front part of the case
- Screw off 2 pcs bolts of the sensor SP5
- By the sensor SP 5 moving in v arc-channel adjust the required flow value, which evokes the contact closing – opening. To adjust the sensor to higher value, it is possible to evoke the contact opening, closing and opening during the operation.
- Retighten 2 pcs bolts of the sensor SP5 thereby fix the sensor.
- Check the free movement of the pointer by its slight turning.
- Close the case in opposite way.

Max. closing current of contact 0,3 A (1 A by request)

Max. voltage 60 V

Max. closing output 10 W

Max. medium temperature 130 °C

We recommend protecting the switch SP5 by connection to locking relay.

- b) continuous reading - SP 6 + converter ECLM with linear output 4 – 20 mA,
twin wire wiring

11 – 26 V_{ss} for Ex

11 – 36 V_{ss} ambient without explosive
hazard

c) Evaluation device DMK - Display of momentary flow, converter with the output e.g. 4
-20 mA or 0 – 20 mA;
Output – contact 250 V 6A

d) Flow indicator ERT 50000 - Display of momentary flow -6 digits
Display of flowed volume, counter A -8 digits
Counter B -7 digits – daily counter
Converter 4 -20 mA , 0 – 20 mA
Power supply 230 V

e) Universal sectional unit PAX – D - Sectional unit displayed the momentary flow or
the flowed volume with the possibility of 4
alarms.
Current output: 4 - 20 mA or 0 - 20 mA

VII. TESTING

The flow meters production covers following tests: material, dimensions, design, surface finish, assembly and marking correctness, tightness and pressure tests. Each device is calibrated individually.

VIII. ORDER

Necessary data:

- Type of the flow meter
- Flow values to be measured during the operation (max, min)
- Measured material
- Pressure
- Temperature
- If it is necessary to sense the flow value – cable length
- Delivery time
- Quantity (pcs)

Example:

We order 1 pc of all-metal flow meter type K 21 for the measuring of the airflow 1600 – 16000 Nl/hr, temperature 20° C, and absolute pressure 201,35 kPa (overpressure 100 kPa).